

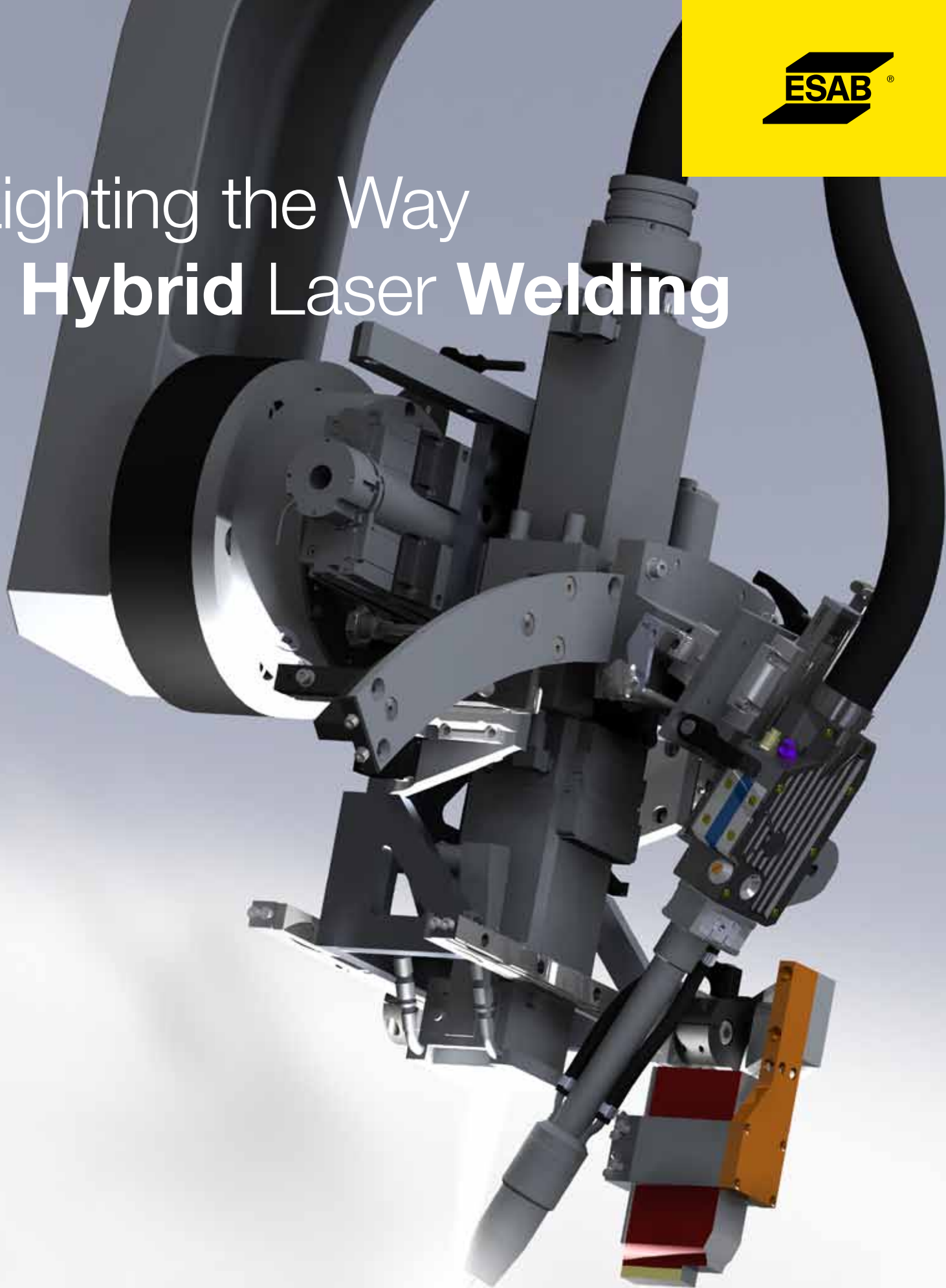

Lighting the Way – **Hybrid Laser Welding**





Hybrid Laser Welding can be used on steel bridge structures to reduce weight and improve fatigue life.



Mobile equipment benefits from the high production speeds and lower construction costs of hybrid welding.

Hybrid

■ So – What Is Hybrid Laser Welding?

Quite simply, the best of two worlds. Combining the key benefits of laser and Gas Metal Arc Welding (GMAW), Hybrid Laser Welding delivers multiple gains, such as radically higher welding speeds and a dramatic reduction in consumable consumption. Sound good? Add enhanced mechanical properties, reduced joint volumes and heat input and greatly reduced part distortion. Sound even better? The introduction of ESAB's fifth-generation Hybrio™ technology launches a new era in advanced welding.

Hybrid Laser Welding combines a high-energy laser beam with conventional arc welding (commonly GMAW) to create an optimal weld pool. The system can be configured in two ways, for different applications: with the GMAW torch leading (butt welds) or the laser leading (fillet welds).

In both of these approaches, the main function of the laser beam is to penetrate the weld joint deeply. Combined with the GMAW process, the laser is able to draw filler metal into the joint to achieve the desired final weld geometry and mechanical properties. The hot spot created by the laser also helps stabilize the GMAW arc (cathodic stabilization) and the weld pool, making the hybrid process much faster than conventional GMAW.

Faster, Cooler, More Productive...

Laser and arc interact to stabilize both processes, resulting in weld speeds far in excess of conventional arc-only systems. In combination with the minimal spot size and deep penetration of the laser, this high travel speed permits welding of thicker total weld throats, with radically reduced heat input compared to conventional fusion welding. Using the hybrid process, a single weld pass may do, where a conventional process might need several.

...and Stronger Too!

Ten years of development and exhaustive tests prove conclusively that hybrid welds are not only generally as strong, durable and ductile as conventional welds, but can in some ways be even better. The low heat input for hybrid welds creates very fine grain structures, minimizing base material dilution, achieving high toughness and making the process especially appropriate for high performance alloys. Compared to conventional welds, these very smooth welds have been shown to improve fatigue limits on fillet welds by a factor of three.

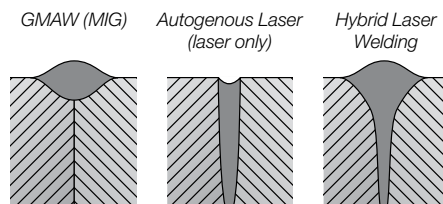

Graphic illustrating differences between GMAW, Laser and Hybrid Laser Welding weld profiles

To reduce material and construction costs, companies are shifting to thinner, high-strength structures, based on high performance alloys. By reducing hydrogen content and making cool, fine-grained welds, the Hybrio™ process ensures consistently high-quality in such alloys while simultaneously accelerating production line throughput.

The process offers many other efficiency gains. These range from higher welding speeds, lower operating costs and increased flexibility to the multiple benefits of a fully automated welding process. And the PC-based touch-screen interface makes manual adjustment history. This enhances operator safety, reduces risk of human error and cuts training costs.

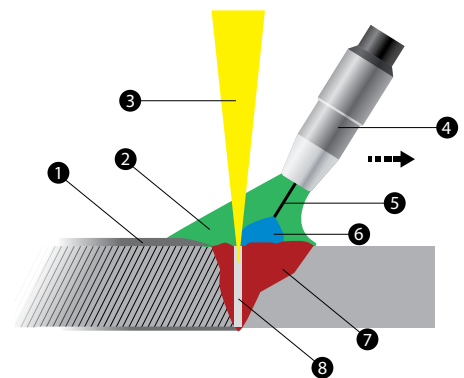

- Hybrid Laser Welding Process
- 1 Newly formed weld bead
 - 2 Inert shielding gas
 - 3 Focused laser beam
 - 4 GMAW torch
 - 5 Wire electrode
 - 6 Electric arc
 - 7 Molten pool
 - 8 Keyhole



Transportation vehicles of all types, from rail to autos to ships, can use hybrid welding in combination with high performance materials, to reduce weight and distortion while enhancing vehicle performance.

How?

■ How Can The Hybrio™ Process Transform My Business?

Hybrid welding is not for everyone. It may mean adjusting cutting/machining operations and require changes to down-stream operations, to fully benefit from the substantial productivity, quality and cost-efficiency gains. Successful implementation assumes access to qualified engineering and technical staff. And introducing such a game-changing new process demands serious investment, not only in terms of resources, but in total commitment from senior management. For those with the right industrial and product profile, though, the potential gains are huge.

A fifth-generation self-adaptive hybrid welding system, ESAB's Hybrio™ technology leads the industry in ease of use and process robustness. By sensing its environment, the joint location

and fit-up, it can adapt the process in real-time to maintain high weld quality over a wide range of fit-up conditions. This offers a major advance in productivity and cost efficiency.

From rolling stock and containers, shipbuilding and the offshore industry to construction, pipeline production and the energy sector, this hybrid process will transform your bottom line. If your business is high-volume industrial fabrication, featuring moderate batch sizes and a low part mix, Hybrio™ could be the answer.

If you plan to compete with a stronger, stiffer, lighter product, using high-strength, low-weight alloys that require a lower heat input – Hybrio™ is for you. The operator-friendly PC interface and flexible, fully-automated weld process will accelerate throughput, significantly enhancing productivity. Furthermore, the unique

characteristics of the Hybrio™ process will slash consumables costs and downstream post-weld treatment requirements. Crucially, you gain a qualitative edge that will generate higher margins.

Gear Up for Higher Speeds, Lower Costs – and a Broader Client Base

Hybrid laser welding is about more than manufacturing capability. It's about growing your business. About enhancing multiple aspects of production. Welding speeds 3-5 times higher than GMAW (and up to ten times higher than Submerged Arc Welding/SAW). Reduced heat input of up to 80% (GMAW) and 90% (SAW). Operational savings of around 50% compared to GMAW, still greater compared with SAW. Most importantly, the unique benefits of deep penetration and low distortion present a whole



new range of exciting product opportunities, based on the huge potential of the latest high-performance lightweight alloys and advanced structure designs.

From Wind Turbines to Aircraft Carriers

Manufacturers across the entire industrial spectrum, from the marine and transport sectors to construction, energy and aerospace, seek to enhance product performance and boost cost efficiency by exploiting the latest high-strength lightweight alloys. The unique benefits of the hybrid laser process now enable the development of new joint types, featuring minimal distortion, increased stiffness and higher strength. Freed from the constraints of conventional welding processes, designers can

now create radical high-performance lightweight structures, based on thin alloy sheet. Laminated, hollow, cellular or of composite materials, these new structures are the building blocks of future industrial success.



ESAB

■ Why Choose ESAB?

Because ESAB is so much more than 'just' an equipment supplier. A respected R&D powerhouse in its own right, ESAB works intimately with end-customers, OEMs and system integrators to achieve optimal welding solutions. This goes beyond the practical and technical challenges, to embrace life-cycle cost and environmental sustainability. As an ESAB customer, you acquire a powerful industrial consultant and partner.

And Why Hybrio™?

ESAB's Hybrio™ technology leads the industry in ease of use and process reliability. The technology can be supplied as a fully-integrated turnkey ESAB welding system, or made available to machine tool OEMs and system integrators as a process package. Customers always have access to the company's comprehensive hybrid welding expertise, with the full support of ESAB Laser Process Centers in North America and Europe.

Profit-Generating Innovation

This fifth-generation welding system features some unique innovations, in particular ESAB's ground-breaking adaptive process control system. Able to instantaneously measure joint position and fit-up quality, it predictively adapts the process in real-time to maintain optimum weld quality across a broad range of conditions. Enhanced weld gap tolerance permits welding of large structures without the need for excessive

machining or fixturing of parts. A seam-tracking camera acquires pre-weld positional and volume data for transmission to the Hybrio™ processor. An optional post-weld inspection camera can be fitted for surface scanning, measurement and automatic defect detection.

This all translates into multiple technical and business benefits: greater versatility and flexibility in large parts and heavy fabrication applications, accelerated throughput, higher productivity, reduced material and downstream costs and improved weld quality.

Exciting Business Opportunities

Whether your focus is beam welding, seam welding, tube or pipe welding, orbital girth welding or multi-axis high flexibility welding, Hybrio™ technology offers significant gains in productivity and cost efficiency. As industry turns increasingly towards advanced structural designs based on lightweight, high-performance and corrosion-resistant alloys, ESAB must anticipate its needs through constant innovation. With the right ESAB technology in place, the market is yours for the taking!

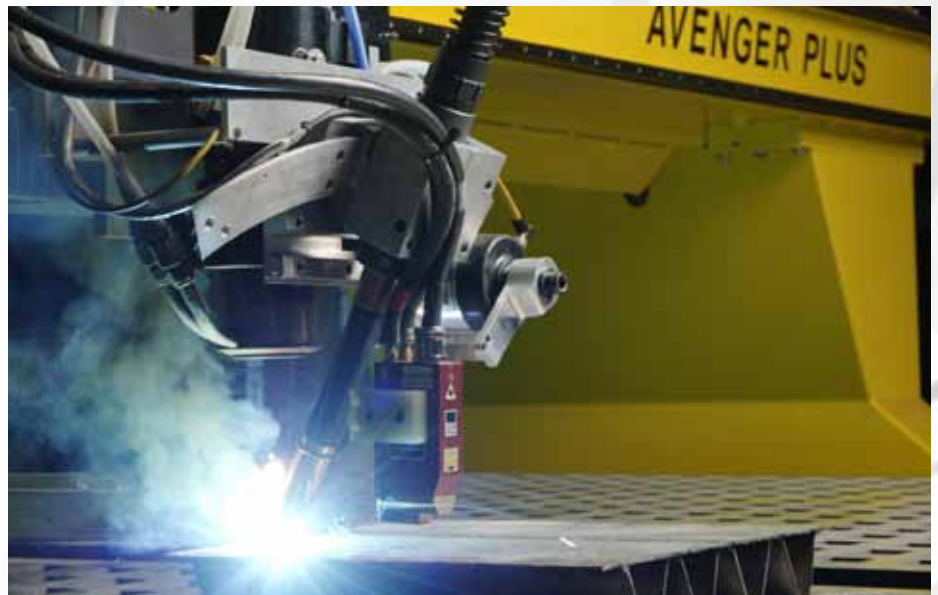



Hybrio™

■ The Hybrio™ Value Proposition:

- Operating costs reduced by 50-80%.
- Productivity improved by 300-1000%.
- Heat input and distortion reduced by 80-90%.
- Reduced weld repair rates.
- Reduced labor content through fully automated operation.
- Reduced operator skill requirement due to easy, PC-based machine controller.
- Lower downstream assembly, welding and finishing costs, through reduced part distortion.
- Higher overall plant throughput and revenue generation.
- Feasibility of new, lighter, stiffer and simpler product design and construction methods.
- Full backing and support of ESAB's process experts and service professionals, with extended warranty and service agreements.

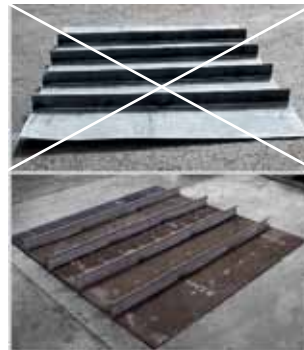

STRENGTH THROUGH COOPERATION

ESAB Welding & Cutting Products / esabna.com / 1.800.ESAB.123

USA: P.O. Box 100545, 411 South Ebenezer Road, Florence, SC 29501-0545

Canada: 6010 Tomken Road, Mississauga, Ontario L5T-1X9

Mexico: Ave. Diego Díaz de Berlanga No. 130, Col. Nogalar San Nicolás de Los Garza N.L. CP 66480 Monterrey, Mexico



FIND US



facebook.com/esabna



twitter.com/esabna



youtube.com/esabweb